

**Wythall Radio Club** meets from 8pm every Tuesday and Friday evening at Wythall House, Wythall Park, Silver Street, Wythall, B47 6LZ, near Birmingham. Visitors are very welcome. **Wythall Radio Club** is affiliated to the Radio Society of Great Britain. Contact g0eyo@blueyonder.co.uk

## Review of recent events

October saw the club's AGM being held. The following members were elected to the following positions;

Chair: Anita 2E0DUO  
Sec; position unfilled  
Treasurer: Ian M0IDR

Committee  
Mike G4VPD  
Roger M0GWM  
Peter M5DUO  
Phil 2E0WTH  
Stuart M0NYP

You will notice a few regular names missing from the list as they chose not to put themselves up for election this year, this is a shame as the club will always need wise counsel but we wish those that stood well and trust them to look after the clubs interests on behalf of all members for the coming twelve months.

There were two constitutional changes also approved by ballot at the AGM. One made the annual fee the same for all members irrespective of age i.e. £20 for individuals and £30 for married couples or families. The other change gave the committee the power to change the fees without the approval

of the membership.

Last year the club invested heavily in new equipment and sorting out the antenna system at the rear of Wythall House. It is encouraging to see the shack equipment being used more often especially for contests. As I write this, I hear the shack is being opened up for the 48hr CQWW SSB weekend.

The annual RSGB club calls contest is scheduled for the 12<sup>th</sup> November starting at 20.00. On top band this is a popular contest and led by Dave G3YXM, the club fields several teams. We often come 2<sup>nd</sup> or 3<sup>rd</sup> but I guess we will be aiming for the top spot this year. Chris G3YHF is getting several members to participate in the RSGB 2m AFS contests on the 4<sup>th</sup> December and with operation from the shack on the cards

John M6KET is looking to start his CW classes for beginners soon and is seeking expressions of interest. There is a regular Tuesday CW session from the shack with the Ancient Order of Gentlemen Operators (John G4JOJL, Les G0HOR and Alf G1MJO) using the club's radios for QSOs where ever they can be found on the bands.

A number of members attended the RSGB Convention in Milton Keynes in early October and a talk by Bob G3PJT on remote station operation was well received by those present. Bob has kindly agreed to come and

give the same talk to the club on Tuesday January 24<sup>th</sup>. We need this to be well supported so get it in your diaries now.

Lee G0MTN reports that the results of the summer IOTA contest are now finalised. Jamie 2E0SDV is confirmed in 2nd place in the Single Op Assisted High Power 24 hr IOTA Fixed station section so well done to him. Unfortunately an entrant submitted their entry in the wrong category, which after the results have been finalised have pushed the club entry down a place from 3rd into 4th in the Multi One IOTA 24 hr section. Lee reports that he is very happy with 4th for our two man single TX effort.

Member Paul G1VLT is recovering from a stroke which has badly affected his left hand side. After three weeks in hospital, Paul is now home. We wish him a speedy recovery.

Callum M0MCX had a serious lightning strike at his QTH. A great deal of damage was done to his vertical antenna, feeder cables, radios (including the TS990S), house televisions and other equipment. Luckily his insurers are being helpful and he hopes for a speedy and satisfactory conclusion to this disaster. See Callum's brief note on what happened on page 8

Lee G0MTN has set up a site for recording club activity online after getting a positive response to the suggestion. The objective is to try to get more people to appear on-air briefly and "check in" even if they can't hang around. The site is <http://wythall-checkin.ddns.net/> Looking at the weekly summary that Lee has produced for the past few weeks activity it looks to have taken off very well.

Don't forget we have the Club's Xmas party to look forward to on Saturday 10th December and of course Xmas Eve sees the start of the famous Wythall Xmas Contest. This starts at 20.00.

**Chris G0EYO**



# Radio from the saddle? Eight lessons before you try!

The warm autumn weather tempted me out pushbike mobile in late September. I explained the equipment set-up in a previous newsletter, so here's what happened!

I already had my homebrew J-pole 2m antenna attached to a 6 foot fibre glass bike safety pole, but would it work on 70cms as well so I could try accessing WL? Before leaving home, I attached the antenna to my bike and powered up through an swr bridge via my Yaesu handheld. Amazingly (I thought - until I worked out the sums!), the swr on the WL frequency 438.550MHz was about 1:1.2, similar to the reading on 145.5MHz. But going down to 433.35MHz pushed it up to 1:3!

So lesson1: WL's input is very close to the third harmonic of 145.5 (436.5Mhz). Well done the WL designers on obtaining an allocation on 438Mhz!

I hadn't been out bike mobile for some time so I put out a test call with the bike propped against the north-facing back wall of our tall house, and back came Dave MOIFT (whose qth is to the south!) to give me a good report. So far so good.

The next day I cycled to Yardley Wood to catch the train to Stratford. Lesson 2: Take the antenna pole off the bike before the train arrives, otherwise it will be too tall to get on the train without terminal bending or a last minute scramble!! I then cycled south-east from Stratford station along the Greenway to Mickleton (where I had a coffee stop) and then (pushed!!) up the very steep Bakers Hill to bring me out on the ridge near Hidcote Gardens. Lesson 3: Always stock up on biscuits to ingest some carbohydrates before attempting a steep hill!!



Near the top (about 160m asl) I got back on the bike, put my headset on, and put out a call on 2m. Immediately, back came Ian MOIDR, who gave me a 59+ from his line of sight location a few miles away. Later I was also called by Dave MOIFT and another station near Stratford.

The road along the ridge extends about 5 miles all the way to Broadway Tower, but some parts were quite busy so it cut

down my radio activity. I tried accessing WL, but it was just too far for my 4 watts. I had a well-earned lunch at Broadway Tower. Lesson 4: However much you think you have earned it, a beer at lunchtime will sap your energy for the ride home!! (Reluctantly, I abstained!). On a more positive note - Lesson 5: Use your lunch break to recharge the handheld from a small SLAB carried in your saddle bag.

Then the cycle back going in a loop south and then east along the high ground (about 300m asl). I worked 2E0UAC south of Coventry, and then Ian again as I started my descent to Chipping Camden for afternoon tea and cake! Lesson 6: It's never possible for cyclists to have too much cake!. Then up the ridge to the east (Ebrington Hill, 260m asl) where I worked a station in Halesowen (about 40 miles - my best DX of the day!!). As I cycled along, I lost this station even though I was still on the ridge. A quick look at 'Hey What's That' showed that the Lickey Hills had interrupted our line-of-sight path! Lesson 7: Bookmark this site on the mobile phone.

There is a wonderful descent from Ebrington ridge along a narrow winding lane to arrive west of Ilmington. When I reached the flat I stopped for my emergency rations - a banana. I had taken a mouthful when, for some strange reason, I decided to swing my leg over the saddle and get off the bike. Suddenly banana, bike and rider crashed to the ground! I'd forgotten there was 6' of antenna pole behind me! Lesson 8: Remember where the antenna is before dismounting.

I then rode back on the flat via lanes and the Greenway to Stratford station. I remembered lesson 2 and lesson 6 while I waited for the train! As I had some time to wait, I remembered lesson 6 again!! But that was because I knew I had to cycle uphill from Yardley Wood station to get home (anyway, that's my excuse!).

A great day out. About 30 miles covered. Fabulous views, fresh air, lots of exercise and cakes - and a little amateur radio! Thanks to Ian and Dave for sharing the day with me!

**Chris G3YHF**





# MORKX's 5.7GHz Microwave Link



and I use the main video carrier to transmit the audio rather than the sub carriers. Simply incorporate these with high gain antennas and you're on the air..

The receive station consists of an RC832 receiver (eBay) mounted directly on the back of a TP-Link 23dB panel antenna (Amazon), powered speaker (Argos), all powered from a 12v gel battery and supported using a tripod speaker stand. Channel 16 on these units is 5.765GHz, which sits nicely in the All Mode section of the



I was first aware of the availability of cheap Microwave gear whilst studying the UKAC contest results tables. Some stations were using equipment described as "FPV" or "modified video senders", using very low power but with great success.

The transmitter and receiver used here are made for the Drone market, to transmit video and audio from craft to ground, and are very cheap from the usual Chinese sources. Modulation is WBFM

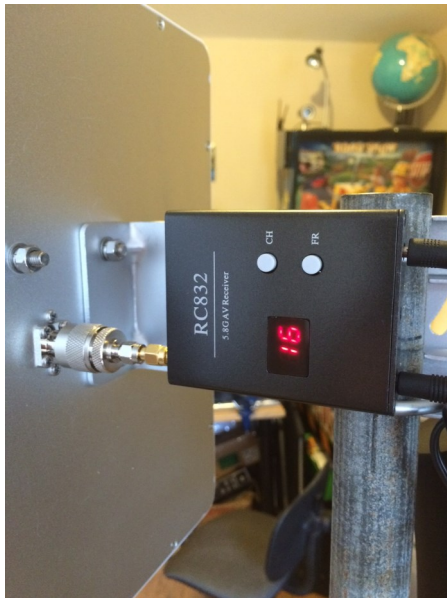

6cm band.

The transmit station consists of a TS832 transmitter (eBay) again mounted directly on the back of another TP-Link panel antenna, interface box (homebrew) and battery.

Tewkesbury, a distance of 12 Miles, the report was 5/9 fully quietening.

Not bad for 600mW and a total outlay of around £150.

**73, Mark MORKX**

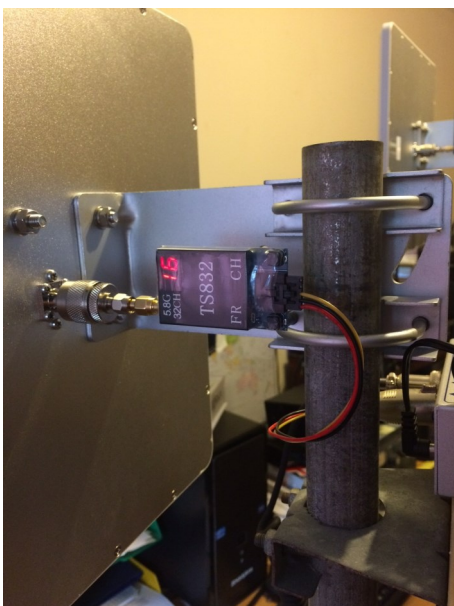

The audio interface is based on a commercial cheap microphone preamp. The inputs stripped out and replaced with an 8-pin plug, wired to suit my Icom voice-keyer mic. The audio output XLR is modified to supply transmitter power and audio to TX (I'm using the main video carrier so connected to Video input). A PTT relay is added to switch 12v to transmitter when keying. The internal voltage regulator was removed to allow 12v battery operation.

The first test across my driveway was an instant success. The audio quality is superb (well there's enough bandwidth!), very loud, the preamp able to drive the 75ohm input with ease. The next test was Evesham (Broadway Tower) to





# EME Experiments

With my HF antenna plans still on hold whilst the wheels of officialdom slowly turn (!), my limited free time to play from home has been focussed on some VHF experimentation. HF Contesting is not the be all and end all of amateur radio – it's good to take a break and try some new things. Whilst I'm not pushing any technical boundaries, trying new modes and building things does align well with the amateur radio licence intent of self training.

So after my successful attempt at meteor scatter (MS) on 144 MHz during the summer, thoughts turned to moonbounce (or Earth-Moon-Earth, shortened to EME.) It must have been 15 years ago I used the single long 144 MHz yagi at the club, with 400w at the antenna, to achieve a moonset QSO with Dave W5UN in Texas using traditional "received by ear" CW. In the intervening years a series of data modes created by (Nobel laureate) Joe Taylor K1JT have revolutionised VHF long distance communications, enabling smaller stations to make EME (and MS) contacts. My challenge was to see what could be achieved at reasonable cost.

I started by thinking what I could put up temporarily, and how it would be supported. I settled on a pair of 8 elements 144 MHz yagis. I chose the G4CQM design this time, as I'd found the Innovantennas LFAs were more robust (i.e. heavy!) than I needed for my use case. These yagis, supplied by Roger Banks from the DXShop, were assembled in minutes.

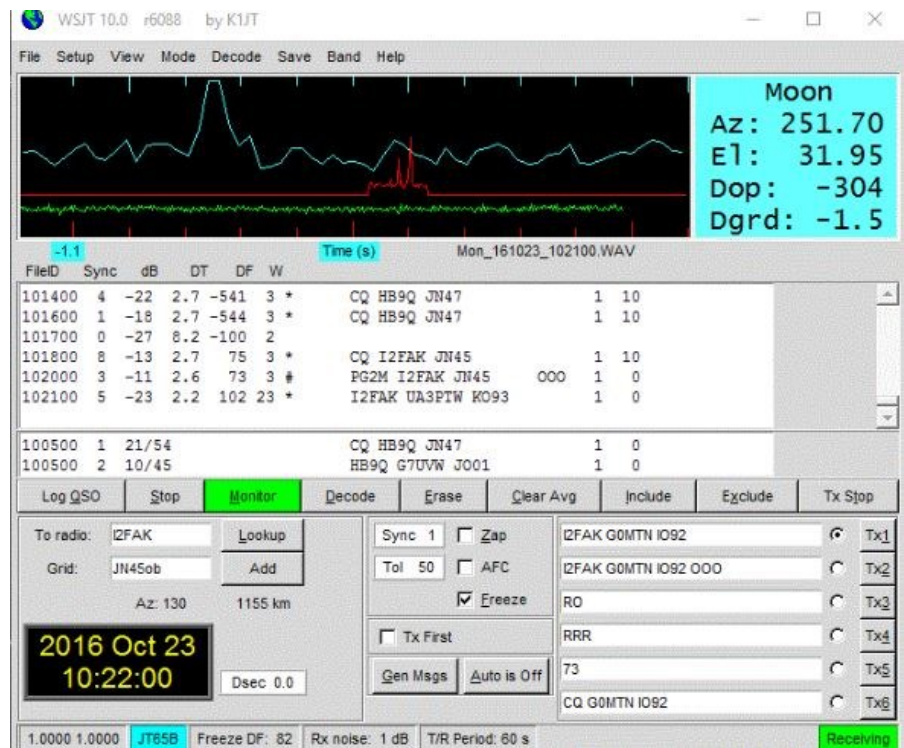

Longer yagis have more gain, but eventually it becomes mechanically difficult to add more elements and gain. Each time you double the number of antennas theoretically up to 3 dB of gain is added. Going from 1 to 2 yagis is quite easy. 8 or 16 antennas is a different engineering challenge altogether.

The antennas were mounted on a frame built up of old 2 inch poles I had around – in previous lives they supported my HF wire antennas at my old house, and also

was the boom of my old C3SS yagi which was retired as it was taken off my old Tennamast in 2013. Some extra crossover plates from Barenco were used to good effect. The support fitted perfectly into an old parasol stand. The antennas are turned by hand as azimuth / elevation rotation would not be cheap or easy, and also I drag the array around the garden to avoid the moon being obscured by trees and buildings. The antennas are taken off when not in use, and the rest of the support can be hidden away. It's probably not a good idea to have yagi elements at low height with children running around anyway.

In the shack I'm using my FT857, which as quite a venerable mobile rig does not have the performance of a more modern base station, or the optimal solution of a high performance transverter driven from an HF transceiver. I did invest in the temperature controlled crystal oscillator unit to minimise drift that would prevent any data modes contacts from working. I have a 160w linear amplifier thanks to Simon G4TVR, which I've mounted alongside a 12V PC fan and under-run it as the full duty 47 second transmit cycle may otherwise be too much for it to handle.

My original Microham Microkeyer that I originally used for CAT control, CW, voice and data keying on HF was



# EME Experiments cont'd

pressed back into action to provide an isolated audio interface for the PC. A delayed PTT output hard keys the linear amplifier to prevent hot switching. After a failed experiment with a relay I had to manually switch the new addition of a mast head pre-amp power before I went into transmit each time.

There is EME activity every day, although more so during organised contest weekends. My first attempt wasn't successful – I wasn't hearing any signals at all. Thinking this was due to the coax loss I invested in a mast head preamplifier and this added sufficient gain that I was able to hear some of the larger stations very clearly both on the speaker and on the software spectrum display. The WSJT software can work with signals very much below the noise, where they would only be visible on screen and not really by ear,

so increasing the number of stations possible to work than via CW.

However, after having a sufficient link budget to receive signals, it turned out that the 120w I was generating in the shack, after the W103 coax loss reaching the antenna, was not enough to get anything other than a QRZ? response from the largest stations active. This was a little disappointing as from online research a few QSOs should be possible at this kind of power level.

Next steps: Simply try again, as moon conditions change from day to day for various reasons there's no room to go into detail here now. Or rather than route the coax feed tidily, go for the "direct route" through a window to cut down on the length used. Another option is to leave the warmth of the shack and oper-

ate /P on the patio, or mount the power amplifier at the other end of the coax run. Lower loss coax and a larger linear amplifier are other options, but this would incur more cost.

The half million mile round trip for a contact remains beguiling, and I can understand how building an EME station can become addictive. Certainly it's easy to appreciate how EME requires understanding of the link budget for transmit and receive, considering the different aspects in the chain that add to and subtract from the gains and losses. To be continued!

**Lee G0MTN**

# Training Report

We have seven on the Advanced Course and six will be sitting their exam on Monday Dec 12<sup>th</sup> at 7pm. We wish them well. We are in the process of sorting out an examination procedure for David 2E0AAI where his disability does not put him at a disadvantage. We have proposed three examinations each of 50mins duration on different dates as being the best way forward. Dave Wilson, M0OBW RCF Quality Manager (and ex RSGB President) has stated "The main things is we do what we can to help David, not find excuses as to why we can't. If it's a one off solution it's a one off solution, so be it" so we are hopeful of finding a solution for when David feels he is ready to proceed.

Roger M0GWM represented the training team at the RSGB Convention and sat in on the discussion on syllabus review. It would seem that some quite significant changes are being proposed to bring the syllabus up to date and to level out the technical transition from Intermediate to Advanced. The new syllabus will probably not go live until 2018 or 2019 at the earliest.

We should be running a classroom and on-line Foundation course in January as we have had a lot of expressions of interest, however when it comes to the crunch it is not unusual for people not to take up the offer.

I provided Ian M0IDR with some training statistics to put in his treasurer's report at the AGM as I know that there has been some discussion in committee on costings and how many students actually join the radio club. We work within RSGB rules with regard to the provision of training in as much as a) we can't make joining the radio club a condition of them joining the course and b) we can only cover our costs and not make a profit from running the course. As part of our classroom foundation courses we do offer students free membership of the radio club until the club year end (about 8 months) and we do factor in our fees a cost towards this. We do this so that students can get the whole picture of what amateur radio is all about and hopefully stay with us. An analysis of the membership list for 2015 would indicate that about 50% of the membership went through a training programme with us. Roger and I will give further consideration in 2017 as to how we can inform students more about the benefits of belonging to the radio club, even if they live out of area or can't make Tuesday or Friday nights. For example we could put a copy of the membership form and the constitution on the memory stick we hand out to each student at the beginning of each course. Perhaps someone from the club could come

and give a 15 minute snappy presentation on one of the class nights as to why people could benefit from joining the radio club.

We also want to make more use of short video home brewed tutorials demonstrating some of the things we try to explain in power point. Dave G3YXM gave a very interesting demonstration of over modulation using an FT817 into a dummy load with an SDR waterfall displayed on the big screen. The increasing bandwidth when overdriving the audio was clearly shown. Making a video of this would be very helpful. I am sure there are other things we could do. So let us have some ideas and volunteers to help with this.

**Chris G0EYO**





# Making a two tone test generator

Two-tone tests are often used to test SSB transmitter output power and gross linearity. The two audio tones used need to be non-harmonically related, and the RF output resulting from each tone individually should be the same amplitude. Then, the RF output of the two tones beating with each other can be used on the scope to measure power and look for gross linearity problems.



As part of the intermediate training we get the students to make up a project to test their soldering and constructional skills. To make it the same for everyone we have specified the project as the Vellerman 1kHz signal generator kit which sells for around £6-£8 depending upon the source. This kit comprises PCB and all the components with assembly instructions. It has jumper clips to enable you to select either sine wave, saw tooth, exponential or square wave outputs. The circuit is based around the NE555 timer chip which can be used to generate a square wave. Using RC components you can convert this pulse into a sine wave.

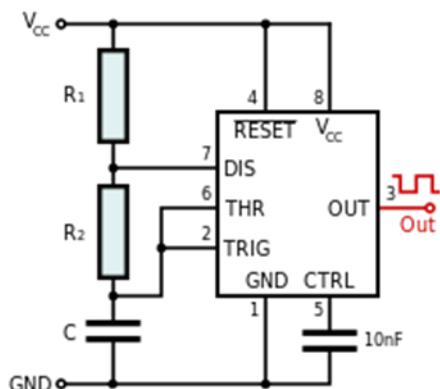

The frequency of the square wave is determined by the components R1, R2 and C. In the Vellerman kit R1 = 1k, R2 = 15k and C = 47nF and this gives an approximate 1kHz square wave.

Two tone test generators require tones which are not harmonically related so 750Hz and 1500Hz frequencies would be unsuitable so I needed to find a suitable low frequency and suitable high frequency. I decided to leave R1 and R2 values as they were originally specified and find a suitable value of C.

Using the formula :

$$f = \frac{1}{T} = \frac{1.44}{(R_1 + 2R_2) \cdot C}$$

I ended up with C being 26nF for 1860Hz and 68nf for 690Hz. The club had a couple of kits which students had left behind as they had failed to work due to poor construction and soldering. (Too much heat from the soldering iron lifting the pads and tracks from the PCB and too many dry joints.

I got one kit working fine on 1kHz and changed C from 47nF to 28nf by putting a 56nF in series with it to give me a calculated  $f = 1858\text{Hz}$ . For the second board I purchased a new kit from Maplins and replaced the 47nF with a 68nf to give an  $f = 683\text{Hz}$ . Checking the outputs on the scope showed that one was indeed a lower frequency than the other.

The signal generator circuit allows some control over output levels so it was relatively easy to set the level of each board at the same pk-pk level. From the scope photograph the pk-pk would seem to be

100mV with the amplitude of both channels set at 50mV/div. The timebase was set at 2mS/div and the upper higher frequency trace would seem to have a  $t = 0.3$  div so this would indicate a frequency of 1666Hz. The lower trace has a  $t = 0.78$  div so this would indicate a frequency of 640Hz. Trying to calculate frequencies from an oscilloscope is not very accurate.

I decided to power both boards from a 9v battery via an on/off switch. The output of each board would be combined to give a two tone output but I also wanted to be able to select either the low frequency output or the high frequency output. This was done with a three way double pole wafer switch. Deciding which lead needed to be soldered to which contact took a bit of working out but I got there in the end.

The two PCB's, the on/off switch, battery, BNC output socket and three way switch were housed in a plastic box (ex Eddy-stone!).

I was fortunate enough to find my label maker after the house move so could label up the switches.

The pictures show the traces in

- A) two tone mode
- B) Low frequency

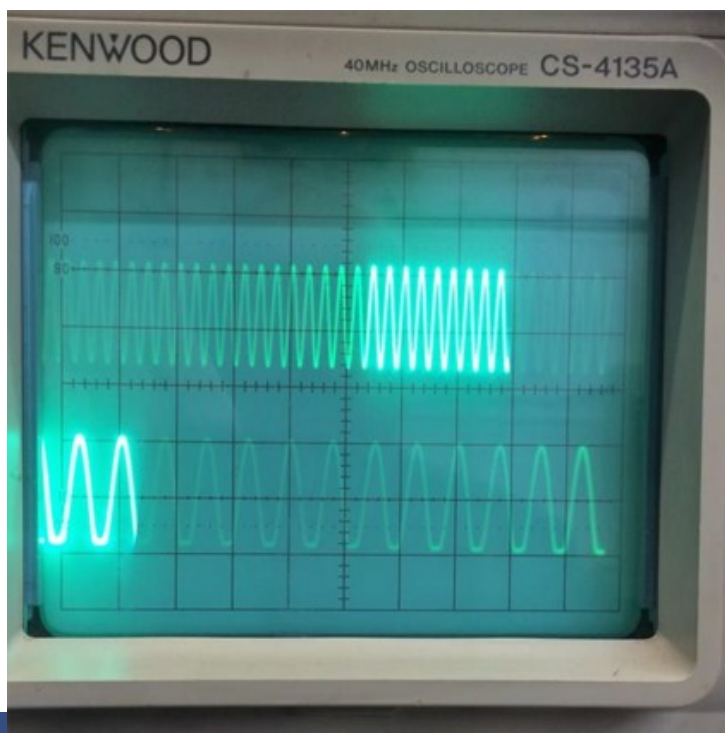

# Making a two tone test generator cont'd

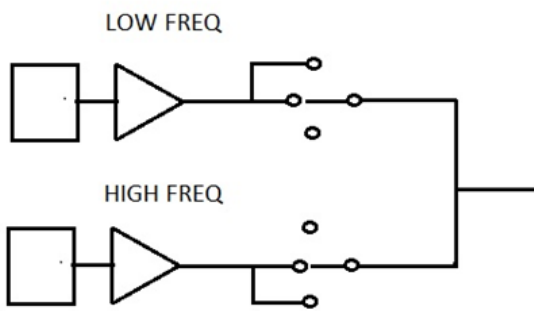

C) High frequency

Now just got to see if 100mV output is enough to drive the mic amplifier on the training HF rig so we can monitor the RF output into a dummy load on an oscilloscope. Here's hoping!

Chris G0EYO

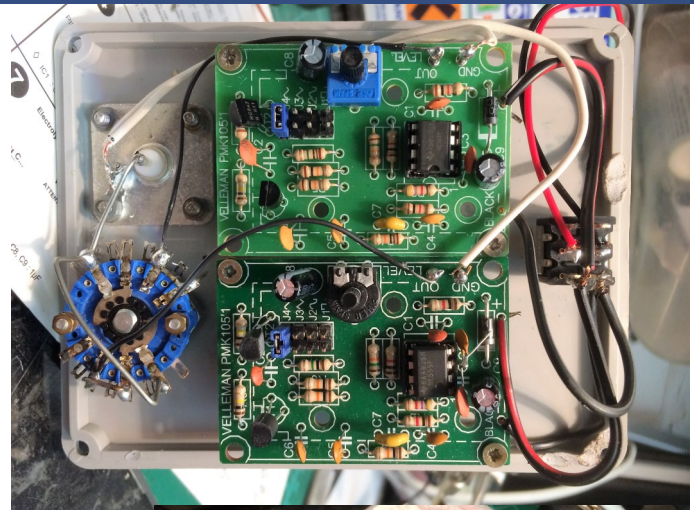

**Output traces: left; 2 tone; middle: low frequency (~700Hz); right: high frequency (~1800Hz)**

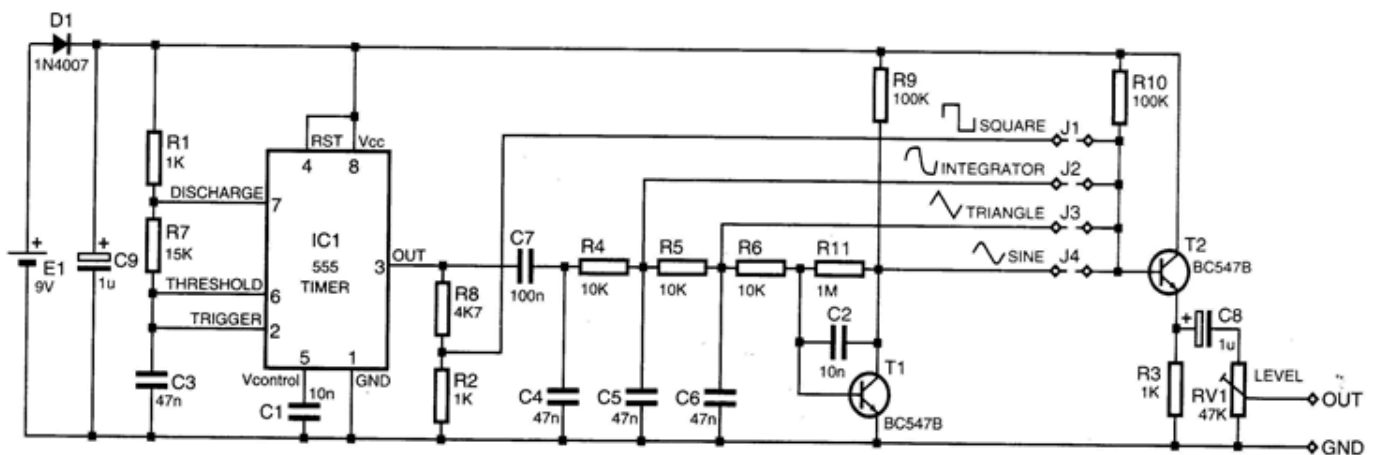
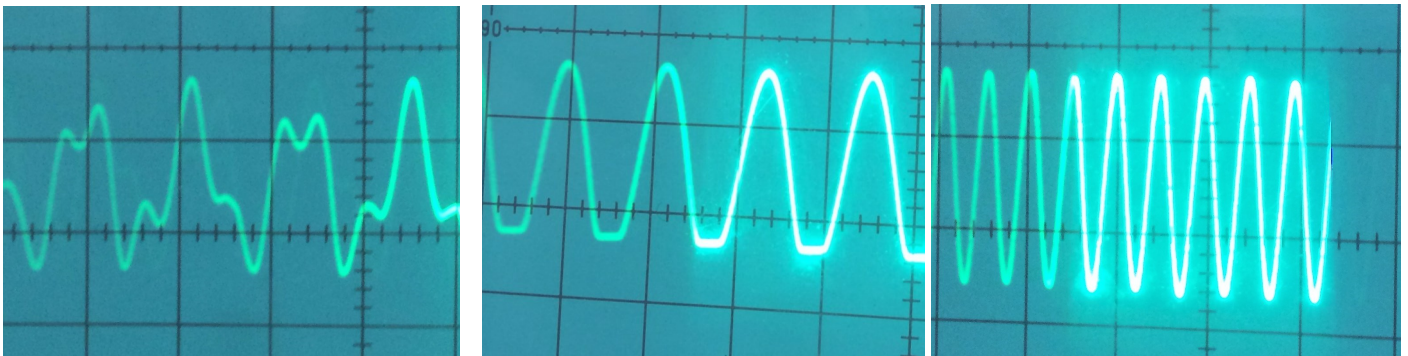



# Lightning Strike at M0MCX QTH

*Callum M0MCX had a direct lightning strike at his Knowle QTH in mid September. He posted a note to the G4WAC Yahoo group which I reproduce here. We hope to get a more detailed article when Callum gets everything sorted and has fully researched the subject with regard to avoiding damage should "lightning ever strike twice"*

It turns out the energy pulse hit the big 10m vertical and started its way down the coax. It saw a connector half way down the pole and flashed to that initially, leaving a rocket gas expulsion jet mark on the pole. It's unfortunate the pole wasn't grounded else I could have saved some gear.

In parallel, somehow the Diamond V2000 also received some energy. There is another jet mark at the join half way down the aerial.

Eventually, the pulse met the first thing it found at the end of the coax, the Palstar AT-4k ATU. From there, it is my guess, it flowed in parallel down the 12v line to the Manson PSU (anything connected to the Manson was fried) and also it found a better ground, the coax to the ACOM 2000 and the TS-990s. From there, it went over the chassis of one (or both) and down the mains lead(s) to the plug block which is connected to a dedicated socket with an emergency switch (near the door).

Here, the energy was pretty hot. It melted the switch on the plug point and made multiple attempts to find earth through anything it could find. Sure, it hit the ring main and rapidly found the consumer unit where it dissipated however, anything fairly near this ring main got quite a belt.

Basically, everything got fried (apart from a couple things). For instance my big K2 power amps are dead. The waterfall of protons weren't too fussy. It went through the mains cable, through the power supply - and it found its way via the XLR connector to the mixing desk. Even the XLR plug has a melt-point where it's grounded. Of course the mixer, the graphic, the speakers.. all fried!

Another for instance, it went up the wall to the plug point that connects to the Virgin broadband box. It went through the box and back out the coax and blew the protection device on the wall.

Most TVs and other electronics that were plugged in on that ring main are fried. We are fully insured and LV are being extremely sympathetic and understanding, noting my slight distressed state! So I will get everything replaced (famous last words!). The spreadsheet I've compiled runs to nearly £20k! Even the central heating appears a bit odd.

Originally, I thought the 999 and the Acom 2000 survived. Actually, the Acom appears to be absolutely fine. The 990 does work, the only issue is that the board that drives the various accessories (USB, amp connectors etc) has fried, so probably repairable with a new board.

Will YOU get hit? I hope not - and Lee mentioned to me that he's only heard of a couple of other "hams" that have been

taken out. So your luck may hold.

When I rebuild the station, I shall fit spark plugs outside to the braid of my coax runs to ground rods. That way, I'm not actually grounding my station permanently, but very high static or certainly lightning will have somewhere to go. It's unfortunate my utility ground (tested last Thursday) is 0.2 ohms, so I'm competing with that.

By the way, disconnecting your coax and plugs may help however I have gas ejection marks on my skirting board even before it got to the ATU. You won't stand a chance. Had it not been the ATU, I'm reliably informed it would punch through a wall to find earth.

Just when I was coming back on air after fitting the deck all summer. Guess I'll be delayed a while.

**Callum M0MCX**



**The next issue of the Wythall Radio Club Newsletter will be published at the beginning of Jan 2017**